

KEYSTONE

Please read these instructions carefully.



This symbol indicates important messages and safety instructions.

Hazard potentials:

- disregarding of instructions
- improper use of product
- insufficiently qualified personnel

Valve application to be within the pressure/temperature limits indicated in the P/T diagram.

Essential points and functions of the valve should be inspected on a regular basis.

When the valve is used in an end-of-line function, PED Cat-I applications are allowed only. For other categories, contact factory.

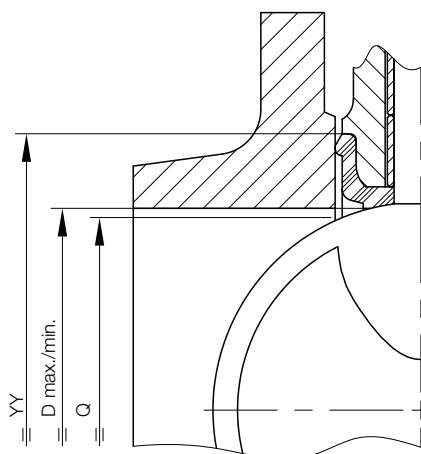

1. Storage & handling

1.1 Protection

Keystone butterfly valves are delivered with protection in accordance with the Keystone Engineering Instructions, to protect the valve seats and disc from damage. Wrapping and/or covers should be left in place until immediately before fitting to the pipe.

1.2 Storage

When valves are to be stored for some time before being fitted, storage should be in the original delivery crates or cases. Storage should be off the ground in a clean, dry indoor area.

1.3 Handling

1.3.1 Packed valves

Lifting and handling of the packed valves in crates should be carried out by appropriate lifting equipment. If a fork lift truck is used, appropriate fork hitches are required.

The lifting and handling of packed valves in cases will be carried out in the lifting points.

The transportation of all packed material should be carried out safely and according the local safety regulations.

1.3.2 Unpacked valves

The lifting and the handling of these valves has to be carried out by using appropriate means and by respecting the carrying limits. The handling must, preferably, be carried out on pallets, protecting the machined surfaces and seat to avoid damage.

When lifting the large dimension valves, the sling and the hooking of the load must be carried out by using the appropriate tools (brackets, hook, fasteners) and load balancing tools in order to prevent the valves from falling or moving during the lifting and handling.

The valve may be lifted only by slings attached to the flange holes or valve body; never to the actuator or the valve opening.

2. Installation



WARNING!

For safety reasons, it is important to take the following precautions before you start work on the valve:

1. Personnel making any adjustments to the valves should utilize suitable equipment. All required personal protection means should be worn.
2. The line must be depressurized before installing the valve.
3. Personnel trained in all aspects of manual and mechanical handling techniques must carry out handling of the valves.
4. Misuse of the valve is not allowed. For example: the valve, handles, actuators or other parts may not be used as "climbing tools".
5. Ensure that valve pressure/temperature limitations marked on the identification tag are within the service conditions. The trim number on the valve's tagplate identifies the valve materials. See Product Manual for valve specific P/T diagram and trim number definition.
6. Ensure that valve materials are compatible with the pipeline fluid.

2.1 Valve inspection

1. Carefully remove the valve from the shipping package (box or pallet) avoiding any damage to the valve or, in case of automated valves, to the electric or pneumatic/hydraulic actuator or instrumentation.
2. Confirm that the materials of construction listed on the valve nameplate are appropriate for the service intended and are as specified.
3. It is not allowed to use third party spare parts. In case of third party spare parts, safe operation is not guaranteed.

2.2 Flange and pipe compatibility

Check matching of flange drilling pattern of valve and pipe before assembly.

Flanges have to meet the following requirements:

- The face inside diameter should be:
 - D min. : The valve Q-dimension + adequate disc clearance.
 - D max. : The inside diameter (ID) of standard pipe for the nominal size ISO 4200.
- If the flange (or pipe) is provided with a raised face, the diameter of this shall be at least 8 mm larger than the YY-dimension of the valve.

The use of the flange-gaskets is not allowed since it might damage the valve.

The Keystone seat-face design eliminates the need for the gaskets.

Use flange bolting in agreement with appropriate standard.



Do not use flange gaskets!

2.3 Valve installation

The valves are bi-directional and may be fitted in either direction relative to the flow. The valve will control flow equally in either direction. The recommended installation position is shaft horizontal and the lower disc-edge opening down-stream. (Especially for slurry service and media with a tendency for sedimentation). For optimum valve control and smooth performance, it is recommended to have a 10 to 20 pipe diameters of straight run inlet piping and 3 to 5 pipe diameters straight outlet piping.

A valve is no crow-bar. Do not use the valve to spread the flanges. Seat damage might be the result.

Notes

- The valve can be installed in the pipe-line either with or without the actuator mounted on top of the valve. Make sure that you can turn the disc cautious so you can feel a mismatch resulting from a disc touching the adjacent piping.
- Do not use the valve as a support of the pipe line construction.
- Adjacent piping must be positioned so that minimal piping stresses are transmitted to the valve flanges during or after installation.
- Handling and lifting of the valves during installation **MUST** be performed following the same instructions described in previous paragraph "1.3 Handling".



Important

Mating flange faces should be in good condition and free of dirt and/or inclusions. Both pipe insides to be well cleaned.

2.3.1. Existing system (see sketch)

1. Check whether the flange distance meets the valve face-to-face dimensions. Spread with adequate tooling the flanges for easy insertion of the valve.
2. In case of a wafer valve, insert some flange bolts in the pipe flanges, to help you bear the valve after insertion.
3. Close the valve so far, that the disc-edge is at least 10 mm within the body.
4. Insert the valve between the flanges, center the valve body and insert all flange bolts. Tighten the flange-bolts hand tight.
5. Slowly open the valve completely. (The disc is in line with parallel flats on stemhead).
6. Maintain the valve flange alignment while gradually removing the flange-spreaders and tighten the flange-bolts hand tight.
7. Slowly close and open the valve to check for adequate disc clearance.
8. Cross-tighten all bolting to the proper torque. Do not over tighten.

2.3.2. New system (see sketch)

1. With the disc in near-closed position center each mating flange with the valve body. Fix the body with some flange-bolts and tighten the bolts.
2. Use the flange-valve-flange assembly for fit-up and centering to the pipe.
3. Tack-weld the flanges to the pipe.
4. Remove the bolting and remove the valve from between the flanges.



Important

Do not finish-weld the flanges to the pipe with the valve bolted between the flanges as this will result in serious heat-damage to the seat.

5. Finish-weld the flanges to the pipe and allow the flanges to cool completely.
6. Install the valve now according to the procedure for installing in existing systems.

2.4. Valve verification

Check the operation of the valve by operating it to "full open" and "full close". To verify the valve operation, the disc position indicator on the actuator or the handle should rotate between the "full open" and "full close" indicators on the actuator or throttle plate. Generally the valve disc travels clockwise to close.

Existing system

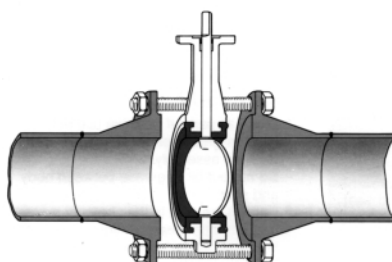

1. Spread the flanges with the adequate tooling. Insert some flange bolts to bear the valve.

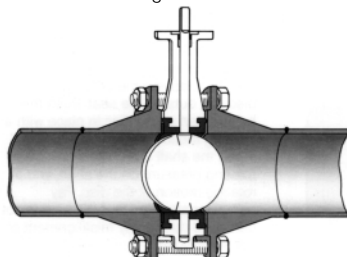

2. Open the valve and remove the flange spreads

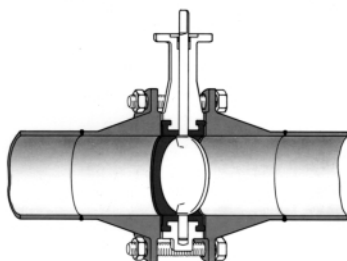

3. Close the valve clockwise, return to open position and cross-tighten all bolting.

New system

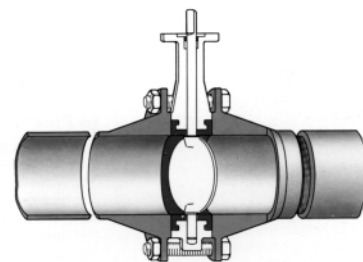

1. Center a flange-valve-flange assembly between the pipes.

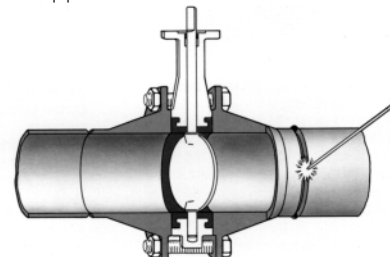

2. Tack weld the flanges to the pipes.

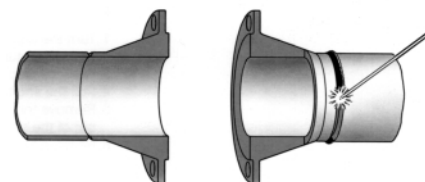

3. Remove the valve and finish weld. Install the valve according to the procedure in the left column.

2.5. Sources of possible danger

This section contains some examples of possible foreseen danger sources.

2.5.1. Mechanical

When manual operators are used, available space should be checked in order to avoid hands being clamped.

2.5.2. Electrical

If static charges can initiate explosions, the valve should be grounded.

2.5.3. Thermal

If the valve is used in applications with a fluid temperature above 40°C the outside of the body might be hot. Sufficient measurements should be taken to avoid burning.

A manual operated valve should be opened and closed with sufficient protection for the personnel operating the valve. For example: protecting gloves.

2.5.4. Operational

Closing a valve too fast may result in waterhammer in the upstream part of the pipeline. Waterhammer results in excessive stresses in the valve and will cause severe damage. Waterhammer should be avoided in all circumstances.

Due to differential pressure across the valve disc, butterfly valves have the tendency to be closed by the flow. Take care when unlatching the valve operating mechanism.

2.6 Troubleshooting guide

Symptom	Possible cause	Resolution
Valve would not rotate	Actuator has failed Valve packed with debris	Replace or repair Flush or clean valve to remove debris
Valve leaking	Valve not fully closed Debris trapped in valve Seat is damaged	Close valve Cycle and flush (with valve open) to remove debris Replace valve
Jerky operation	Debris trapped in valve Air supply actuator inadequate	Cycle and flush (with valve open) to remove debris Increase air supply pressure and/or volume

3. Maintenance

The Keystone butterfly valves figure 320 are designed to require a minimum of maintenance.

WARNING!

Depressurize and, if necessary in case of dangerous fluids, drain the line and flush with appropriate cleaning fluid before starting any maintenance. Failure to do so may cause serious personal injury and/or equipment damage.

Before disassembling the valve, ensure the valve has been decontaminated correctly from any harmful gasses or liquids and that it is within a safe temperature range for handling.

Personnel making any adjustments to the valves should utilize suitable equipment. All required personal protection means should be worn.

Only personnel trained in all aspects of manual and mechanical handling techniques must carry out handling of all valves.

3.1 Routine maintenance

Routine maintenance or lubrication is not required other than periodic inspection to ensure satisfactory operation and sealing.

3.2 Removing the valve

1. Turn the disc to nearly closed position. (The disc is in line with the parallel flats in the stem).
2. Loosen all flange bolts and remove the bolts.
3. Spread the flanges with adequate tooling, and remove the valve.

3.3 Valve disassembly

Disassembly is not possible. The shafts are press-fitted into the disc during the production at factory.

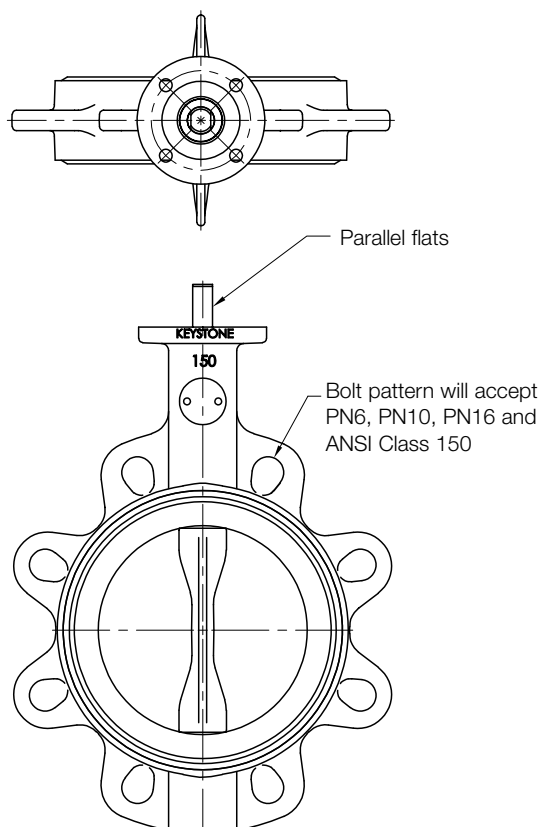
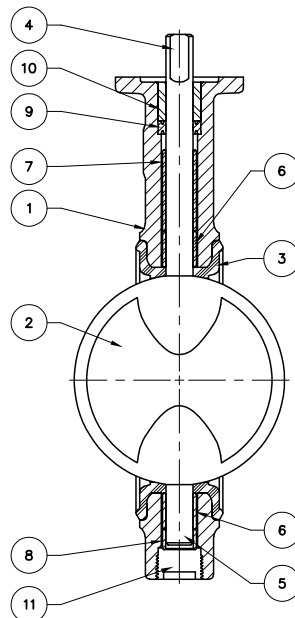

Figure 320



Parts identification

- | | |
|----------------|-------------------|
| 1. Body | 7. Upper spacer |
| 2. Disc | 8. Lower spacer |
| 3. Seat | 9. Packing |
| 4. Top stem | 10. Upper bushing |
| 5. Bottom stem | 11. Plug |
| 6. Bushing | |