

KEYSTONE

VALVE USA, INC.

FIGURE 129/139 INSTALLATION AND MAINTENANCE MANUAL

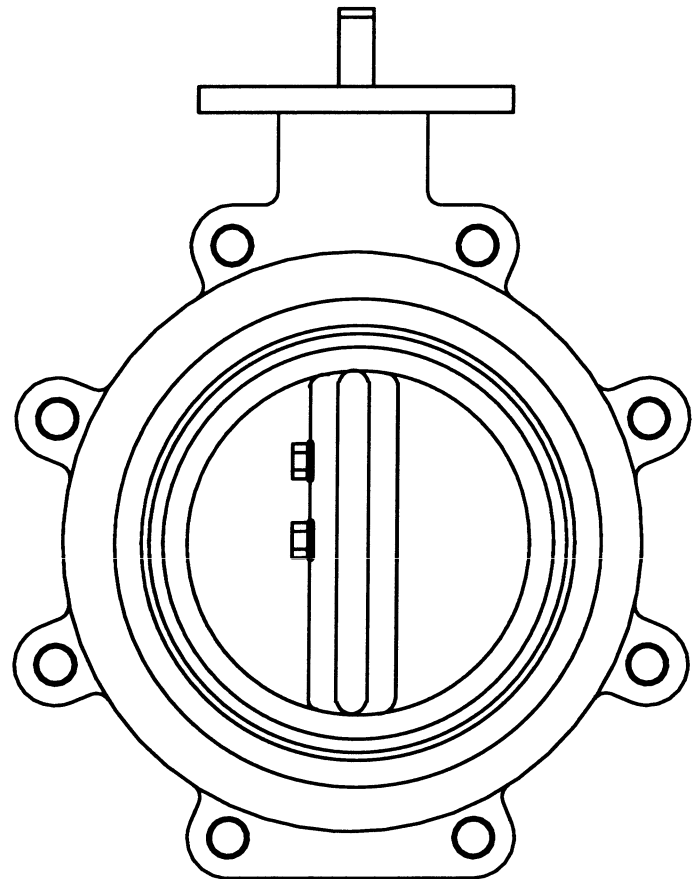
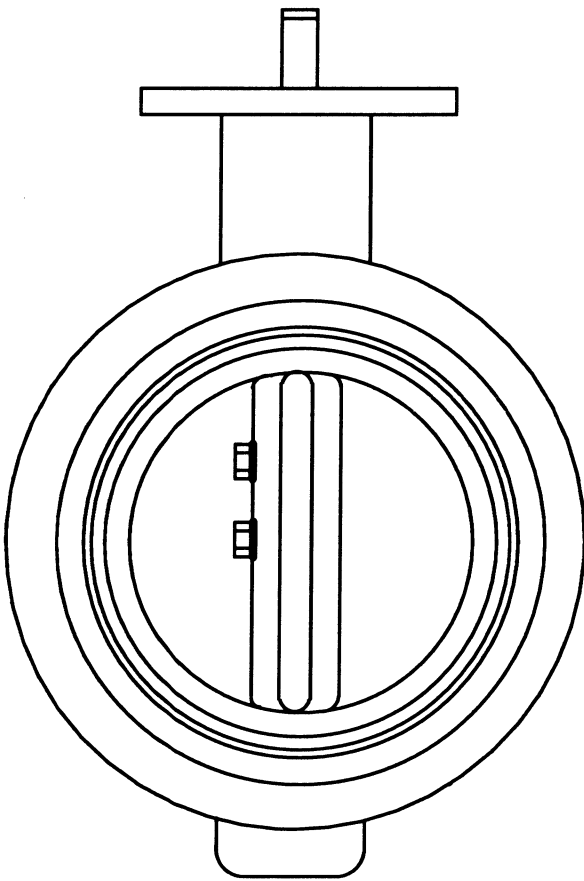

TABLE OF CONTENTS

FIGURE 129 AND 139 BUTTERFLY VALVES INSTALLATION AND MAINTENANCE MANUAL

<u>PARAGRAPH</u>	<u>TITLE</u>	<u>PAGE</u>
1-1	SAFETY PRECAUTIONS	1
1-2	INTRODUCTION	1
1-3	SERVICE LOCATIONS	1
1-4	EQUIPMENT CHARACTERISTICS	2
1-5	VALVE INSTALLATION	2
1-6	INSTALLING THE FIGURE 129 AND 139 VALVES	2
1-7	VALVE MAINTENANCE	3
1-8	SCHEDULED MAINTENANCE	3
1-9	VALVE DISASSEMBLY	3
1-10	DISASSEMBLY OF THE FIGURE 129 AND 139 VALVES	3
1-11	ASSEMBLY OF THE FIGURE 129 AND 139 VALVES	3

<u>ILLUSTRATION</u>	<u>TITLE</u>	<u>PAGE</u>
1-1	VALVE IDENTIFICATION	1
1-2	FIGURE 129/139 VALVE PARTS	4

<u>TABLE</u>	<u>TITLE</u>	<u>PAGE</u>
1-1	TROUBLESHOOTING THE VALVES	5

FIGURE 129/139 BUTTERFLY VALVES INSTALLATION AND MAINTENANCE MANUAL

1-1 SAFETY PRECAUTIONS. The following precautions appear in text in this manual, and are repeated here for emphasis.

CAUTIONS:

Read the installation instructions before attempting installation.

Obtain replacement parts only through Keystone Valve U.S.A., Inc. or through one of its authorized distributors.

Disc screws should always be replaced when removed from the disc. Commercial screws are unacceptable as replacements.

Never attempt to perform maintenance on or remove an actuator from a valve that is in service. Close the valve that is just upstream and then downstream from the valve prior to performing maintenance.

1-2 INTRODUCTION. This manual covers the description, installation, operation, and maintenance of Keystone Figure 129 and 139 butterfly valves.

1-3 SERVICE LOCATIONS. For service or technical information, contact the following:

Keystone Valve U.S.A. Inc.
P.O. Box 40010, Houston, TX 77240
(713) 466-1176 FAX: (713) 937-5466
TELEX: 166-038 OR 775-265

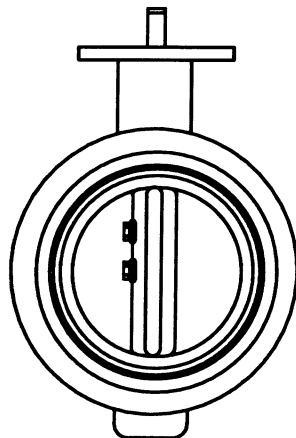

FIGURE 139

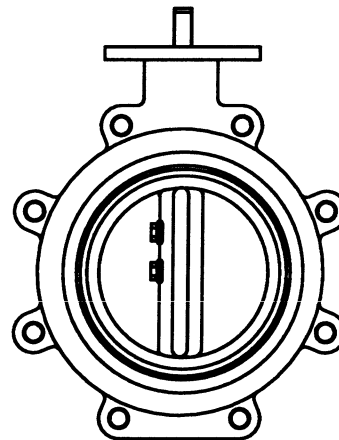

FIGURE 129

ILLUSTRATION 1-1 VALVE IDENTIFICATION

1-4 EQUIPMENT CHARACTERISTICS.

VALVE	STYLE	PRESSURE RATING (PSI)	ANSI FLANGE STANDARD	GASKETS
FIG. 129	LUGGED	200	125/150 LB.	DO NOT USE
FIG. 139	WAFER	200	125/150 LB.	DO NOT USE

1-5 VALVE INSTALLATION.

CAUTION:

Read the installation instructions before attempting installation.

1-6 INSTALLING THE FIGURE 129 AND 139 VALVES.

1. Lined pipe, heavy wall pipe, or flanges must have a minimum allowable inside diameter at the centered body face to clear the disc seating edge when opening the valve. Refer to the "Q" dimension on the appropriate valve drawing (see the Table of Contents) for the proper value.
2. The 129 and 139 valves are non-directional, controlling flow equally well in either direction.
3. To install the valve between existing ANSI flanges, the flanges must be spread sufficiently before placing the valve in position to prevent distortion and/or damage to the seating face of the seat.
4. In new construction, with the disc **slightly open**, do the following:
 - a. Figure 139 valves only—Center each companion flange bore to the body face bore. Span the valve body with the flange bolting and tighten.
 - b. Figure 129 valves only—Align and center the companion flange bolt holes to the valve body lug holes. Assemble the body and flanges with the flange bolting and tighten.
 - c. Use the flange-body-flange assembly for fit-up and centering to pipe. Tack weld the flanges to the pipe.
 - d. Remove the valve from the flanges. **Do not finish weld the flanges to the pipeline with the valve bolted between flanges.** Doing so will result in damage to the valve seat.
 - e. Finish welding the flanges to the pipeline and allow to cool completely before attempting valve installation.
5. When installing the valve/actuator assembly, the disc should be slightly open with the disc within the valve body and at least 3/8" way from the body face.
6. After spreading the flanges, center the valve body between them.

7. For the figure 139 valves, span the valve body with the required flange bolts. For the figure 129 valves, assemble the valve body to the flanges with all flange bolts possible.
8. Turn the disc to the full open position and tighten all flange bolting hand-tight. Slowly close the valve clockwise) and check for adequate disc clearance.
9. Return the valve disc to the full open position. Cross-tighten all bolting to the proper torque specifications of the flange bolts.
10. Again, check for adequate disc clearance.

1-7 VALVE MAINTENANCE.

1-8 SCHEDULED MAINTENANCE. There is no routine or scheduled maintenance required for the valves. Lubrication is not required. Valves should be cycled at least monthly to insure trouble free operation.

1-9 VALVE DISASSEMBLY.

CAUTIONS:

Obtain replacement parts only through Keystone Valve U.S.A., Inc. or through one of its authorized distributors.

Disc screws should always be replaced when removed from the disc. Commercial screws are unacceptable as replacements.

Never attempt to perform maintenance on or remove an actuator from a valve that is in service. Close the valve that is just upstream and then downstream from the valve prior to performing maintenance.

1-10 DISASSEMBLY OF THE FIGURE 129 AND 139 VALVES.

1. Open the disc 45°. Remove actuator and stem extension if applicable.
2. Remove the disc screws (see Ill. 1-2 pc. 6), and o-rings (pc. 7). Remove the upper stem (pc. 3) by pulling up using a back and forth rotating motion. The bushing (pc. 5), and packing (pc. 9) may come out with the stem.
3. Remove the seat (pc. 4), and seat o-rings (pc. 8) by pushing the seat straight out of the body. Discard part to be replaced.

1-11 ASSEMBLY OF THE FIGURE 129 AND 139 VALVES.

1. Clean all reusable parts. Use Silicone base lubricant to facilitate assembly
2. Install the seat o-rings (see Ill. 1-2, pc. 8) into the outside edge of the seat stem bore holes. Insert the seat into the body bore making sure to align the stem bore holes. Install the stem (pc. 3) using rotary downward pressure and insuring parts alignment. Make sure that the seat is not damaged due to misalignment of the stem bore holes. Back the stem out until the bottom of the stem is just inside the top body stem bore hole.

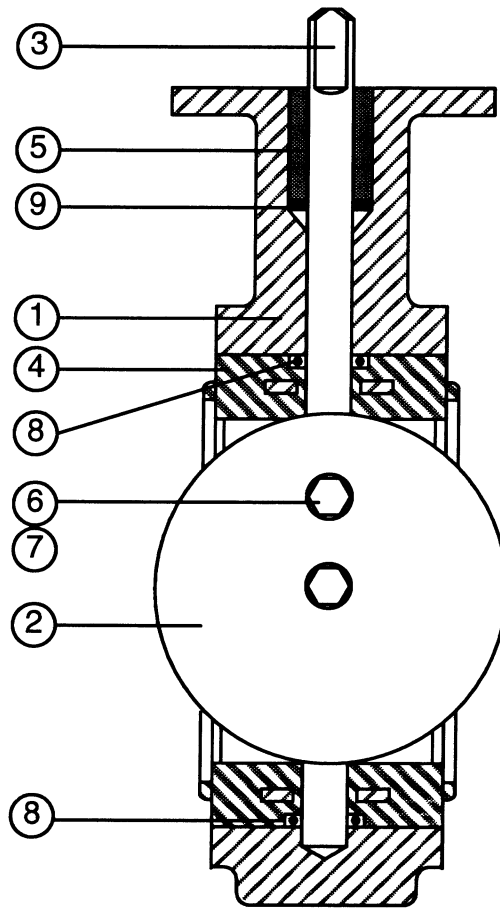

**ILLUSTRATION 1-2
FIGURE 129/139 VALVE PARTS**

3. Install the valve disc into the valve with the disc screw holes toward the valve top plate at a 90° or right angle using a rolling motion (top to bottom), or by pushing straight in slightly past the body stem bore holes and then pulling back for stem bore hole alignment.
4. Place the o-rings (pc. 7) onto the disc screws (pc. 6) and install into the disc/stem assembly hand tight.
5. Install the packing (pc. 9), and bushing (pc. 5).
6. Tighten the disc screws securely.
7. Install actuator and cycle valve several times to assure proper operation.

**TABLE 1-1
TROUBLESHOOTING THE VALVES**

SYMPTOM	PROBABLE CAUSE	SOLUTION
VALVE OPENS ONLY A FEW DEGREES AND STOPS. (IT WILL NOT OPEN TO THE FULL ANGLE DESIRED.)	IMPROPER INSTALLATION. (THE VALVE IS IMPROPERLY ALIGNED.)	LOOSEN THE FLANGE BOLTS, REALIGN THE VALVE WITH FLANGES, AND RETIGHTEN THE FLANGE BOLTS. (CROSS-TIGHTEN TO CORRECT TORQUE PER ANSI REQUIREMENTS.)
LEAKAGE PAST THE FLANGE FACE.	1. THE FLANGE BOLTS ARE NOT EVENLY TORQUED.	1. LOOSEN THE FLANGE BOLTS AND TORQUE THE BOLTS DOWN IN PROPER SEQUENCE.
	2. IMPROPER FLANGES.	2. REPLACE THE FLANGES.
LEAKAGE IN THE CLOSED POSITION. (LEAKAGE IN THE LINE.)	THE VALVE DISC IS NOT CLOSING FULLY: 1. THE ACTUATOR IS NOT ADJUSTED PROPERLY.	1. REFER TO THE MANUAL FOR ACTUATORS.
	2. DAMAGED VALVE STEM.	2. REPLACE STEM.
	3. DAMAGED VALVE SEAT.	3. REPLACE SEAT.
	4. DAMAGED VALVE DISC.	4. REPLACE DISC.
	5. LINE PRESSURE EXCEEDS THE VALVE'S MAXIMUM WORKING PRESSURE.	5. REDUCE THE LINE PRESSURE.
LEAKAGE AT THE STEM.	PACKING/BUSHING FAILURE.	REPLACE PACKING/BUSHING.
WATER HAMMER.	THE VALVE IS CLOSING TOO QUICKLY.	ADJUST ACTUATOR.
EXCESSIVELY HIGH TORQUE.	1. OBSTRUCTION IN LINE.	1. REMOVE VALVE FROM PIPELINE AND REMOVE OBSTRUCTION.
	2. VALVE STEM OR DISC BENT. (CHECK FOR WATER HAMMER OR FREEZING OF LINE MATERIAL.)	2. REPLACE DISC OR STEM.
	3. SCALE BUILD-UP ON STEM AND SEAT.	3. OPEN AND CLOSE THE VALVE SEVERAL TIMES. OPERATE THE VALVE AT LEAST MONTHLY. CHECK THE VALVE SEAT FOR DETERIORATION.